

MATCH LETTER OR NUMBER WITH PRINT

DATE: 11/19/2019

MODEL: AST612SA

ORDER NUMBER: 000000

DEALER: BRAVO

PG: 1 OF 1

- 1 .030 ALUM. EXTERIOR W/CAP
- 2 DOUBLE REAR DOORS
- A 1-32" SIDE DOOR
- B 24" ATP STONEGUARD
- C 2-FLOW THRU SIDEWALL VENTS

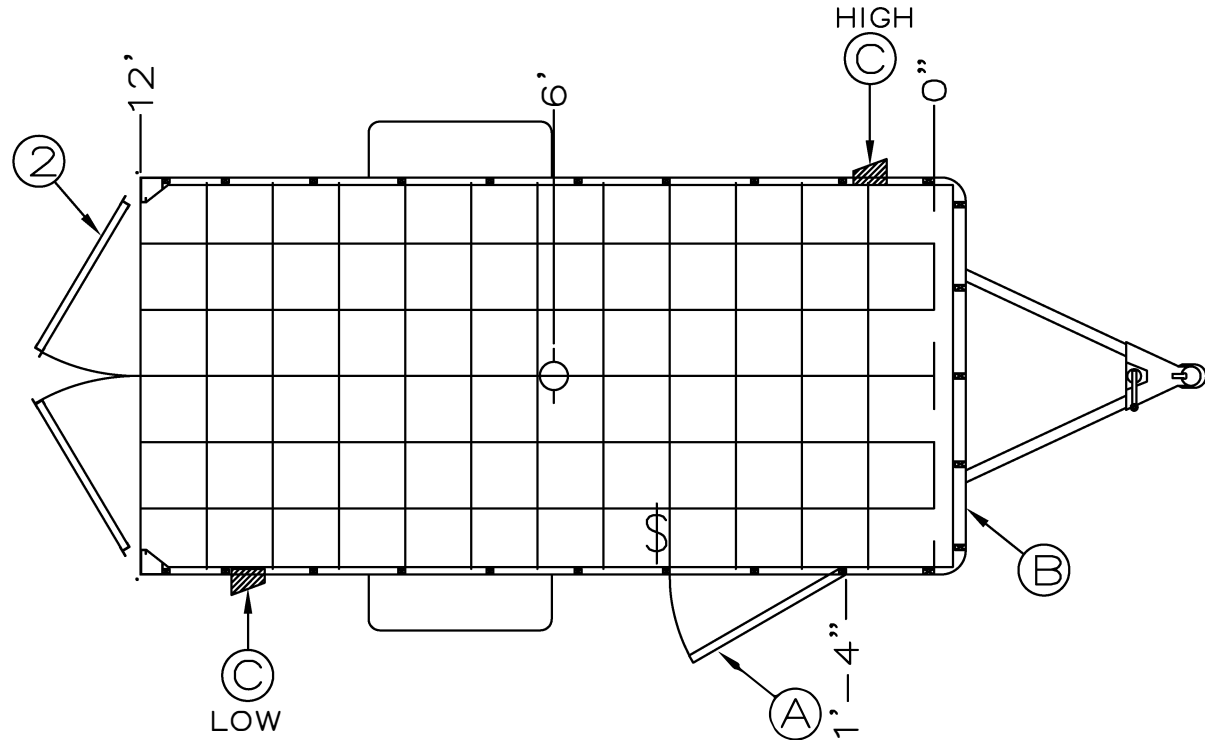

KEY: :

12 VOLT ELECTRICAL	110 VOLT ELECTRICAL	ROOF VENTS	
<ul style="list-style-type: none"> - STANDARD LED DOME LIGHT - 4" ROUND LED DOME LIGHT - WALL SWITCH 	<ul style="list-style-type: none"> - PANEL W/ LIFELINE & CABLE HATCH - MOTOR BASE PLUG - 2 BULB FLUORESCENT - 1 BULB FLUORESCENT 	<ul style="list-style-type: none"> - QUARTZ LIGHT - WALL SWITCH - 15 AMP RECEPT - 20 AMP RECEPT - GFI RECEPT 	<p>N/P</p> <p>N/P = NON POWERED 12v = 12 VOLT POWERED 110v = 110 VOLT POWERED A/C = AIR CONDITIONER W/F = WIRE & FRAME</p>
			<ul style="list-style-type: none"> X - D RING E - E TRACK - ATP (T/C) - TIRE COMPARTMENT
			<p>REVISION: _____</p> <p>APPROVED: _____</p> <p>BRAVO TRAILERS</p> <p>19319 COUNTY ROAD 8, BRISTOL IN 46507 PHONE: 574.848.7500 - FAX: 574.848.7550</p> <p>DRAWN BY: XXXXX</p>