

MATCH LETTER OR NUMBER WITH PRINT

DATE: 11/19/2019

MODEL: AST714TA2

ORDER NUMBER: 000000

DEALER: BRAVO STOCK

PG: 1 OF 1

1 .030 ALUM. EXTERIOR W/CAP
2 DOUBLE REAR DOORS

A 1-32" SIDE DOOR
B 24" ATP STONEGUARD
C 2-FLOW THRU SIDEWALL VENTS

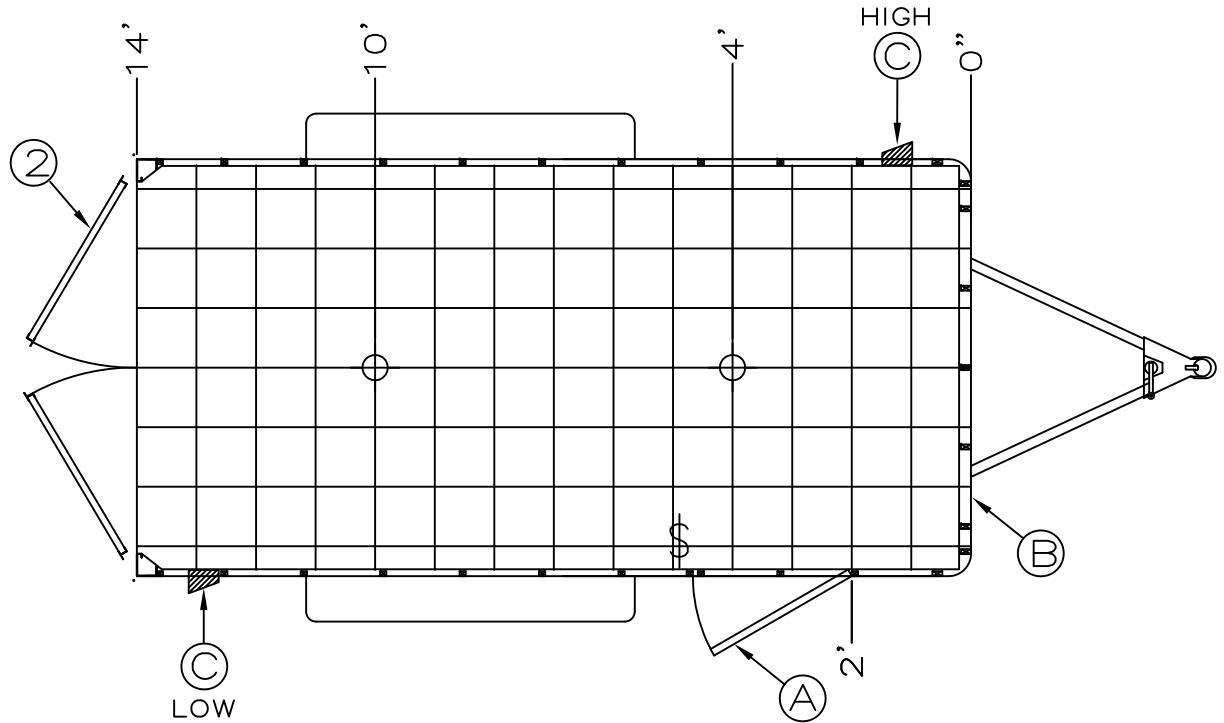

KEY: :

12 VOLT ELECTRICAL	110 VOLT ELECTRICAL	ROOF VENTS		REVISION: _____
<ul style="list-style-type: none"> - STANDARD LED DOME LIGHT - 4" ROUND LED DOME LIGHT - WALL SWITCH 	<ul style="list-style-type: none"> - PANEL W/ LIFELINE & CABLE HATCH - MOTOR BASE PLUG - 2 BULB FLUORESCENT - 1 BULB FLUORESCENT 	<ul style="list-style-type: none"> - QUARTZ LIGHT - WALL SWITCH - 15 AMP RECEPT - 20 AMP RECEPT - GFI RECEPT 	<ul style="list-style-type: none"> - N/P - D RING - E TRACK - ATP - TIRE COMPARTMENT 	<p>APPROVED: _____</p> <p>BRAVO TRAILERS</p> <p>19319 COUNTY ROAD 8, BRISTOL IN 46507 PHONE: 574.848.7500 - FAX: 574.848.7550</p> <p>DRAWN BY: XXXXX</p>
		<p>N/P = NON POWERED 12v = 12 VOLT POWERED 110v = 110 VOLT POWERED A/C = AIR CONDITIONER W/F = WIRE & FRAME</p>		